

# MATERIA

## BOHEMICA

### *Destined to Dazzle*

stars Violet Chachki as the fortune teller alongside Preciosa's newest crystal innovations.

### **A Second Chance to Shine**

Preciosa partners with prestigious Academy of Arts, Architecture and Design in Prague for newly launched deadstock crystals initiative.

PRECIOSA



**PRECIOSA**

A



As I write this, we end a very trying yet commercially successful calendar year. Reeling supply chains and a steep rise in energy costs were met with unprecedented demand and saw the strengthening of Preciosa's business relationships across the globe. This, I think, is a testament to each of Preciosa Components' 1,700+ team members, whose unwavering dedication to servicing our customers in the face of much uncertainty continues to astound me.

Across industries, maintaining a network of reliable business partners and suppliers is now more important than ever. Preciosa strives to be and to maintain both. Key to our long-term strategy is to continue to source as many raw materials as we can locally, both for ecological and logistical reasons but also simply because they are of the highest quality. In this issue, our head of purchasing, Petr Ježek, sheds some light on the advantages and challenges of this strategy.

Among these pages you will also find a dazzling showcase of our latest crystal innovations, including a brand-new color worn spectacularly by a very special guest star. This season, we are also proud to announce the addition of Preciosa's own collection of prefabricated crystal transfer designs, specifically intended to help our network of business partners spread more responsibly sourced sparkle.

Sincerely,

**Jan Štiller**  
Sales & Marketing Director  
Preciosa Components



Published by  
Preciosa, a.s.

Director  
Jan Štiller

Head of Marketing  
Eva Švihovská

Editorial  
Colleen Klei  
Michal Štastný  
Florence Li  
Doris Huang  
Wendy Huang

Graphic Design  
Lukáš Ráček  
Petra Veselá Matyščíková



# CONTENTS



## 6 Where the Magic Happens / The Secret Agents of Sparkle

Glass recipes are complex, not to mention highly protected secrets. Known only by a handful of trusted employees—each privy only to his or her piece of the puzzle—these recipes with their long lists of coloring agents are any glassmaker's most valuable asset. And Preciosa has... well, a few.

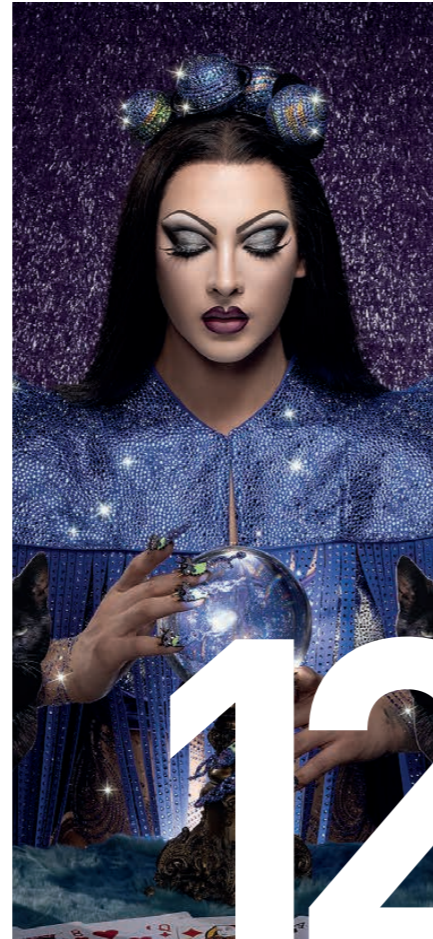

## 12 Fashion Editorial / Destined to Dazzle

Inspired by our reinvigorated fascination with mysticism, astrology and soft magic, *Destined to Dazzle* is a surrealist psychic reading starring Violet Chachki as the fortune teller alongside Preciosa's newest crystal innovations.



## 32 The Multifaceted World of Preciosa / Petr Ježek, Head of Purchasing

From diamond powder to coveralls and everything in between, Preciosa Components' head of purchasing, Petr Ježek, oversees the acquisition of it all.

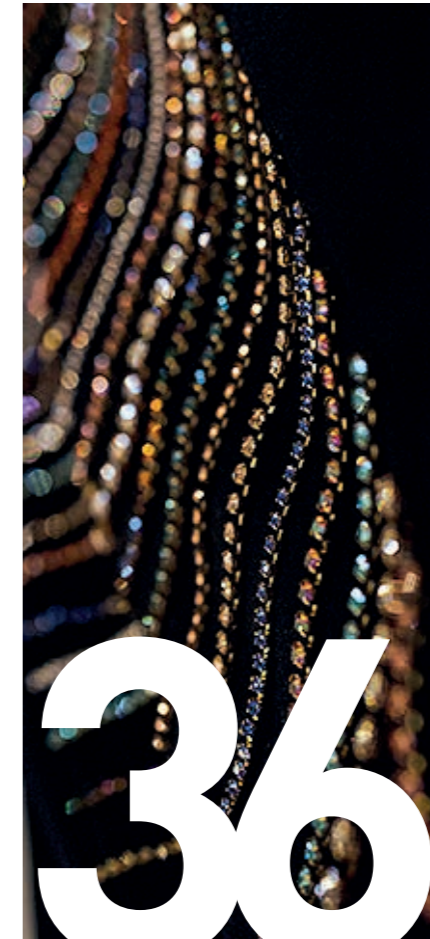

## 36 A Second Chance to Shine / UMPRUM

Preciosa partners with the prestigious Academy of Arts, Architecture and Design in Prague for newly launched deadstock crystals initiative, Preciosa RE/Inventory.

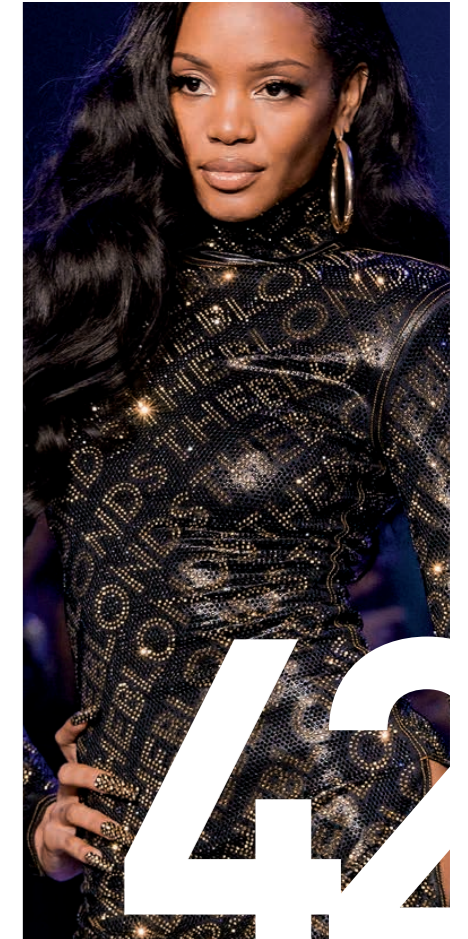

## 42 Crystals on the Catwalk / SS 2023

From New York to Shanghai, catwalks shone bright with crystals by Preciosa last season.



\*  
where  
the magic  
happens

# THE SECRET AGENTS OF SPARKLE

Glass recipes are complex, not to mention highly protected secrets. Known only by a handful of trusted employees—each privy only to his or her piece of the puzzle—these recipes with their long lists of coloring agents are any glassmaker's most valuable asset. And Preciosa has... well, a few.

From the smallest machine-cut crystal in the world to gigantic lighting installations that span several stories, Preciosa's portfolio of premium glass and crystal products is incredibly diverse. And part of what makes them premium is their apparent consistency.

Take our signature clear Crystal color, for example. Whether the batch is melted to produce size ss16 chaton roses or the long, vine-like arms of a chandelier, once the glass is blown or cooled, cut and polished, the color—Crystal—must look exactly the same. And although the end result is supposed to be identical, the recipes for these batches differ considerably. The intended finished product—be it a chaton rose or the arm of a chandelier—determines the specific ratio of ingredients, that is, the recipe required to achieve visual consistency across our vast portfolio.

"This depth of knowledge and intuitive knack for knowing how a procedure later in the production process may affect the color of the glass is not learned overnight," says color specialist, Květa Sázavová. "We are talking about decades of experimentation and de-

velopment, which is what makes each recipe so invaluable – I believe there are things that we can achieve with glass that no one else in the world can."

And she means this literally. Preciosa's seed beads division alone is able to produce more than 800 different glass colors, many of which are not found anywhere else in the world. The group's largest division, Preciosa Components, which also produces chandelier trimmings for Preciosa Lighting, offers an astounding 25,000 shape-size-and-color combinations, requiring more glass recipes than any one person can keep straight.

"When you consider that it is not as simple as getting the color right at any cost, the variety is truly remarkable," she adds. "Not only do we have to factor in the final use of the glass—say, whether it will be for a multi-story chandelier that is hung on a moving ship or the detailed embellishment of a luxury handbag—we must also consider other factors, such as desired cooling temperature and the environmental implications of every ingredient."





\*  
where  
the magic  
happens

► Cadmium is a great example. Traditionally, the coloring agent for red glass, cadmium (a chemical element) is harmless in its inert state but emits toxic fumes when melted, like for example during glass production. In 2018, Preciosa introduced Red Velvet, a cadmium-free true red glass as an alternative to traditional industry-standard shades like Siam and Light Siam. And while most coloring agents are not environmentally harmful, others come with their own set of challenges like sourcing and price. Gold, for example, is used as the principal ingredient for Preciosa's pink shades like Rose, Light Rose and Indian Pink; a combination of gold and silver is used to color Padparadscha.

The advantage of precious metals, like gold and silver, is that they are considered strong coloring agents—meaning only tiny amounts are required to color entire batches—but others, including oxides of rare earth metals like erbium or cerium are weaker, not to mention more expensive to source. Light Peach, Gold Quartz and Light Gold Quartz require a combination of erbium, cerium and titanium; green hues like Erinite and Limecicle include another rare earth metal, praseodymium. And the list goes on.

“I can of course openly speak about our coloring agents in general terms since many of their properties are well known throughout the glassmaking industry,” adds Květa. “It is the precise ratios that are kept secret—even from most of the people who work with them—because they are, frankly, irreplaceable.”

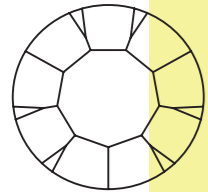
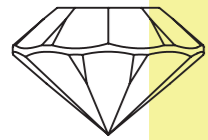
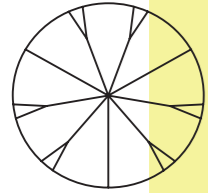

“Not only do we have to factor in the final use of the glass, we must also consider other factors, such as desired cooling temperature and the environmental implications of every ingredient.”

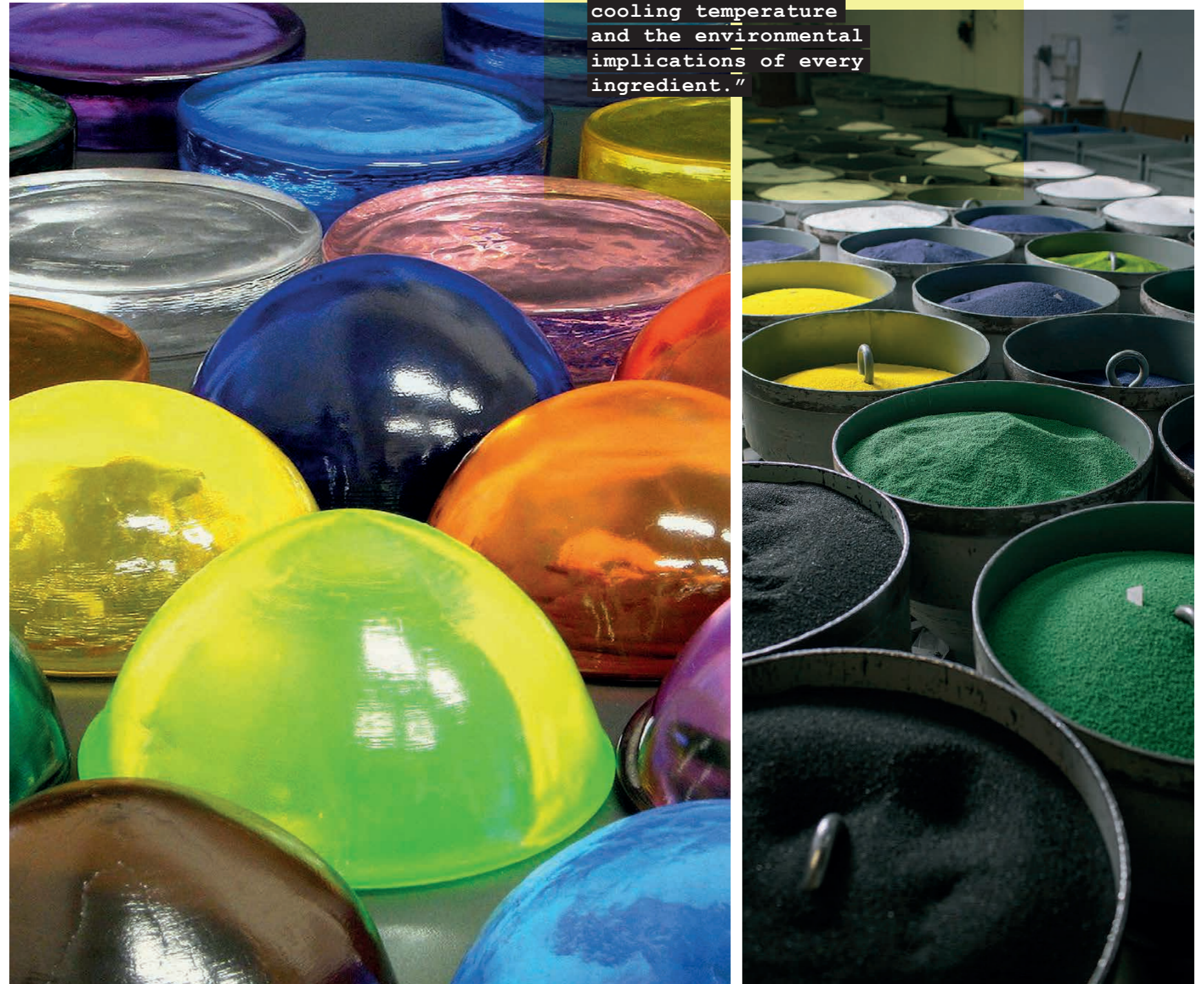
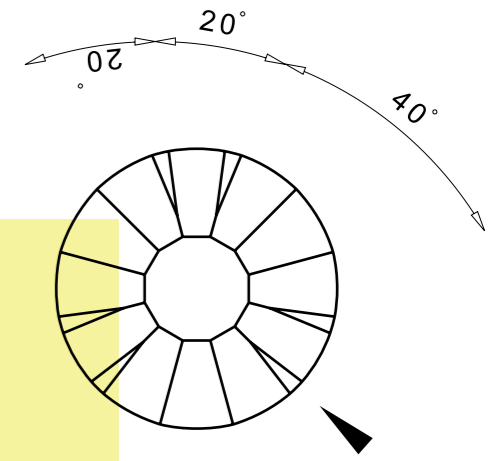



# MAXIMA

PRECIOSA® PREMIUM LINE

Preciosa's premium quality MAXIMA line is unmatched in both shine and character. A testament to Bohemia's world-class sand, which gives our crystals their signature sparkle, these stones are among the best lead-free crystals available on the worldwide market today. Our Hi-Pure Crystal™ production process guarantees exceptional clarity and brilliance while our patented gold and silver Dura-Foiling™ layers ensure lasting durability and excellent light dispersion.



100% made in the  
Czech Republic

Enhanced  
application  
durability

Lead-free  
brilliance

100% made in the  
Czech Republic

Enhanced  
application  
durability

Lead-free  
brilliance





# Destined to Dazzle

STARRING  
MADAME  
BLUE VIOLET  
CHACHKI



Photography  
 Michaela Karásek Čejková

Creative Direction and Styling  
 Tereza Šikulová, Preciosa  
 Soňa Dermeková, Preciosa

Talent  
 Violet Chachki  
 Jana Tvrdíková

Make-up and Hair  
 Kateřina Koki Mlejnková

Nails  
 Michaela Jančíková

Photography Assistants  
 Antonín Blažek

Backstage Photography  
 Jan Dolejší

Fashion Credits  
 Lukáš Krnáč  
 Tereza Rosálie Kladošová  
 Silky Gang Prague  
 Jarda Praha

Special Thanks  
 Mumm  
 Malfy Gin







Corset House of Canney





Preciosa crystal net top Jarla Praha Trousers Lukáš Krnác



# There is sparkle in your future.

Said the psychic to the girl  
Sat there in silence  
Under the neon-lit *Knows all, sees all, tells all* sign on the door.

The planets aligned  
The black cats purred  
Mere figments in a crystal ball, swirling  
She said not a single word.

It is clear to me now,  
The universe's secrets have unraveled.  
My cards never lie.  
You are destined to dazzle.







Hat Lukáš Krnác





Corset House of Canney, Gloves Silky Gang Prague





love





   @CrystalsByPreciosa

[destinedtodazzle.preciosacomponents.com](http://destinedtodazzle.preciosacomponents.com)



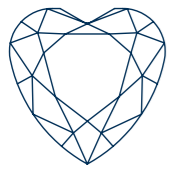

SHINE  
R E S  
P O N  
S I B L Y

# HOW WE TREAT PEOPLE SAYS A LOT ABOUT OUR COMPANY.

## How we treat our people says a lot about our company.

As a family-owned business, and one of the largest employers in the Liberec region, Preciosa strives to provide more than just a job. We believe that sustained investment into the wellbeing of our employees, both in and outside of the workplace, is just as important to Preciosa's success as the products we sell. The average length of employment at Preciosa is 16 years, and the Group is continuously among the most desirable companies to work for in the Liberec region according to the country-wide Employer of the Year contest, having been awarded the top spot five times in the past 10 years.

In addition to above-standard wages and working conditions, we offer our people a variety of benefits that support a healthy work-life balance. As one of the largest companies in the region, Preciosa frequently employs more than one member of the same household; often, partners with young children. Family is one of the company's core values and is supported by relevant benefits like flexible working hours for non-shift workers, a company-funded, tuition-free kindergarten, discounted tickets to sporting events and a series of annual "fun days" for Preciosa employees and their children.

Preciosa also offers subsidized catered meals for all employees, as well as complimentary work-related transport and even onsite accommodation in our company-owned dormitories. Preciosa executives are encouraged to seek out opportunities to further their personal and professional development, like business seminars and language lessons, all of which can be financially supported by Preciosa. The Group also owns several lakefront cottages accessible exclusively to employees and organizes summer camping trips for employees' children.



### Did you know?

Retired Preciosa employees receive discounted lunches from our onsite canteens for the rest of their lives? If you visit one, you will often see retirees meeting for lunch.





*Interview with  
Petr Ježek, head of  
purchasing*

From diamond powder to coveralls and everything in between, Preciosa Components' head of purchasing, Petr Ježek, oversees the acquisition of it all. Together with his team, Petr is responsible for the regular purchase of thousands of different materials needed for everything from production to machine maintenance and is a steadfast believer in quality.

**A**fter sixteen years in Preciosa's purchasing department, Petr Ježek is by now somewhat of an expert in purchasing rare and expensive commodities, like silver and gold.

Which might come as a surprise given that Preciosa is a producer of glass, not jewelry. But there are many surprising things about Petr's job and by extension the large-scale production of more than 25,000 different crystal components. We sat down with Petr just before the holidays to discuss the trials and tribulations of purchasing in the post-Covid era, how Preciosa vets its many suppliers and the importance of testing, testing, testing!

Let's begin with the kinds of materials you and your team purchase. Can you give us some examples? What is the most expensive material? The most important? The most expensive materials (by far) are precious metals. These account for the largest percentage of the costs because we buy a lot. For instance, Preciosa purchased more than 13 kilograms of gold during the first half of this fiscal year alone, which is used primarily as a coloring agent and for metallic coatings. We also buy a lot of silver – roughly 300 kilograms every year, which we use for foiling. And then there is platinum, which is needed primarily for auxiliary products such as furnace dischargers or platinum melting pots used both for experimentation with new glass recipes as well as large-scale production of some specific colors.

If we changed the geographical source of the sand, we would have to change all our glass formulas, and some may not even work at all. I cannot overstate how important sand is to our business.

By volume, our largest annual purchase is sand, which might seem obvious given that it is the single most important ingredient for glassmaking. Preciosa's Components division alone consumes around 600 tons of glass sand every year, all of which is sourced locally. Because it is so important, it is crucial that we maintain a stable source, as the slightest change could impact the quality of our product. Glass sand from different areas of the world contains varying levels of

trace minerals like iron, for example. If we changed the geographical source of the sand, we would have to change all our glass formulas, and some may not even work at all. I cannot overstate how important sand is to our business.

**What is the most challenging aspect of your work?** The most challenging aspect is also the most important, which is making sure that our production is never slowed down or limited due to lack of materials, especially now with the recent increase in demand. Not only does this extend to raw materials used in the actual glass mixtures, but also materials needed to produce and maintain our machinery and tools. A good example of this type of material would be diamond powder (basically, monocrystalline synthetic diamonds) or cerium oxide, which are used for cutting and polishing discs.

Our work is definitely more demanding these days. Precious metals and rare-earth oxides are bought and sold according to daily market price and markets this year have been extremely volatile. Some have fluctuated by as much as 100% during the past six months.

Another example would be detergents used to wash the semi-finished stones during production, which is surprisingly and technologically sensitive as the detergent needs to wash off any impurity caused by the machinery without damaging the stones. We are buying tens of tons of detergent every year, and—like with the sand—the smallest change could cause major problems in production. It is not only about price – any change in supplier needs to be approved both by production and R&D.

**Global supply chains are still recovering from disruptions caused by the pandemic and gas and electricity are now exponentially more expensive in Europe as a result of the war in Ukraine. How has this affected purchasing specifically?** As was the case in pretty much every industrial sector, we noticed an increase in prices across the board, longer delivery times and complications with availability as well as logistics and transport – exciting times! And before the supply chains



► could recover from the pandemic, they were of course affected by the war in Ukraine. In some market segments, the situation is still precarious though the availability of many materials has improved already. Some, however, have gotten worse – for example, automation and electric parts, for which delivery times can easily reach up to 45 weeks. It is also challenging to find alternative suppliers both because of our stringent quality testing and/or because the availability of materials changes rapidly with many of them. Our work is definitely more demanding these days. And, of course, we are affected by the ever-present price increase of the raw materials. Precious metals and rare-earth oxides are bought and sold according to daily market price—much like the stock exchange—and markets this year have been extremely volatile. Some have fluctuated by as much as 100% during the past six months.

When it comes to vetting the suppliers, we perform a thorough audit which always includes an in-person visit to the factory to ensure among other things that the supplier has sufficient quality control procedures in place.

**Wow, that is a lot. Can you give us an example? How did your team handle it?** The craziest example would be rhodium, which we use for various purposes including plating metal settings. The price shot up by three or four hundred percent overnight, so we had to find an immediate solution to replace rhodium wherever possible. For example, our platinum melting pots that I mentioned earlier are a mixture of platinum and rhodium. We had to find a way to replace the rhodium because the price of even a tiny amount would have been more expensive than the price of much more platinum! It was a lot of back and forth with R&D, but, fortunately, we managed.

**It seems like a huge part of your job is the purchase of precious metals. Where do they come from? Is the procedure very complicated?** It is. Suppliers of precious metals and their products undergo a relatively standard certification process – this is more straight forward than say the purchase of rare-earth oxides, such as cerium, erbium or praseodymium. They are called



rare-earth oxides because they are just that – rare. Some of these elements cannot be bought anywhere outside of China, as it is the only country with naturally occurring deposits. Given the problems with transportation during the past two years, we decided to stock up on some of these materials to ensure we have enough to continue production even when waiting on a longer-than-usual delivery time.

**How does Preciosa vet its suppliers? Is it a complicated process?** Our suppliers of strategic materials are rated by annual assessment that covers all aspects of our business relationship. Materials classified as “strategic” are highly sensitive and very important to our production, so we are careful of any changes within any of the companies that supply them. Sometimes we get offers for slightly cheaper materials, but we won’t even consider it until it has been thoroughly tested. If we necessarily need to make changes to any of our ingredients, we must first consult with our production

team, or, if the change is really significant, we send everything to be tested by R&D before it gets used in small-scale production to see if there is any detectable difference in appearance, behavior or quality. Only then will we begin using material from a new supplier. When it comes to vetting the suppliers, we perform a thorough audit which always includes an in-person visit to the factory to ensure among other things that the supplier has sufficient quality control procedures in place. We also ask for references, look at the company’s history and verify its accreditations.

**What do you enjoy most about your job?** Honestly, the people I work with.





# A SEASON OF CHANGES SHOPIZED

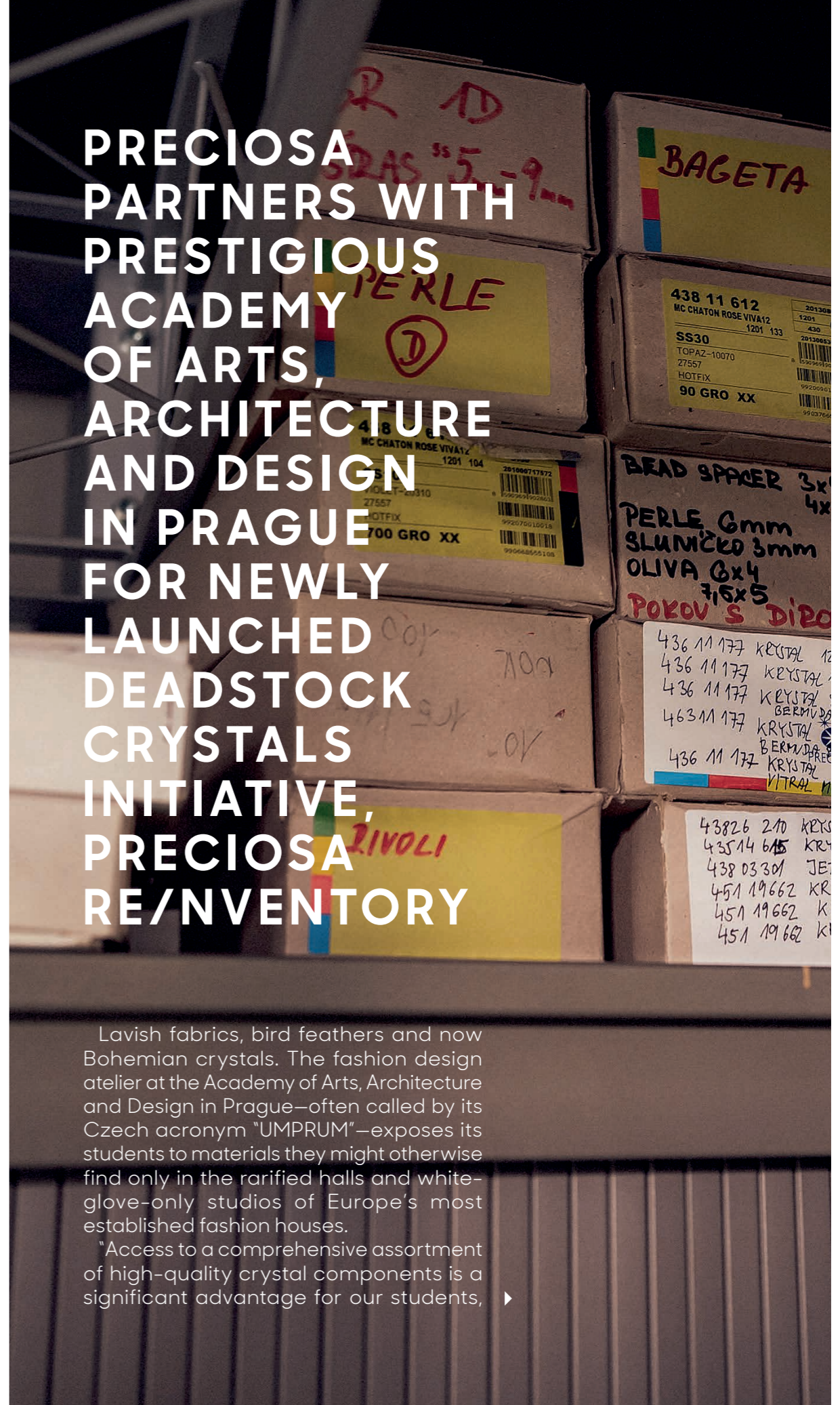

## PRECIOSA PARTNERS WITH PRESTIGIOUS ACADEMY OF ARTS, ARCHITECTURE AND DESIGN IN PRAGUE FOR NEWLY LAUNCHED DEADSTOCK CRYSTALS INITIATIVE, PRECIOSA RE/INVENTORY

Lavish fabrics, bird feathers and now Bohemian crystals. The fashion design atelier at the Academy of Arts, Architecture and Design in Prague—often called by its Czech acronym “UMPRUM”—exposes its students to materials they might otherwise find only in the rarified halls and white-glove-only studios of Europe’s most established fashion houses.

“Access to a comprehensive assortment of high-quality crystal components is a significant advantage for our students, ▶



A S E C O N D  
 C H A N G E T O S H O P I N G  
 C H A N G E T O S H O P I N G  
 A S E C O N D

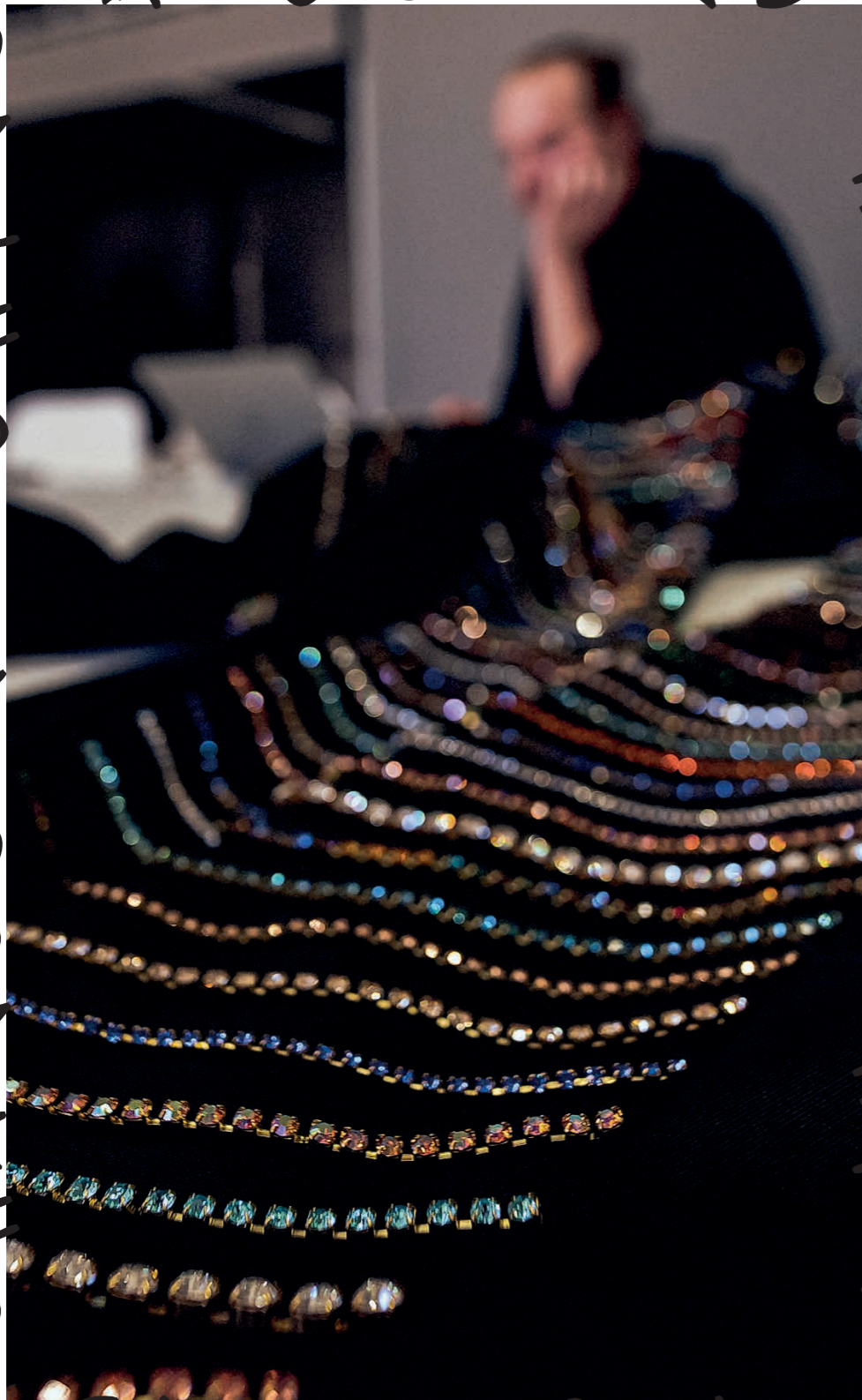

► and not only for the obvious reason of stimulating creativity," says head of the fashion design atelier and UMRUM alum, Miroslav Sabo. "This partnership gives them hands-on experience with technical application methods and high-end embellishment that is seen as cost-prohibitive-prohibitive in many commercial environments."

While courses on practical skills such as pricing and business planning are an important part of the curriculum, the greatest emphasis is placed on developing individual technique and thinking about the future of the industry, which is undoubtedly circular (and hopefully crystalized).

"We work in small batches and love to experiment so RE/INVENTORIED crystals are ideal for us," says UMRUM student, Jan Smejkal. "Personally, I consider the sparkle of Preciosa stones to be one of the key design elements that elevates our collections to the next level."

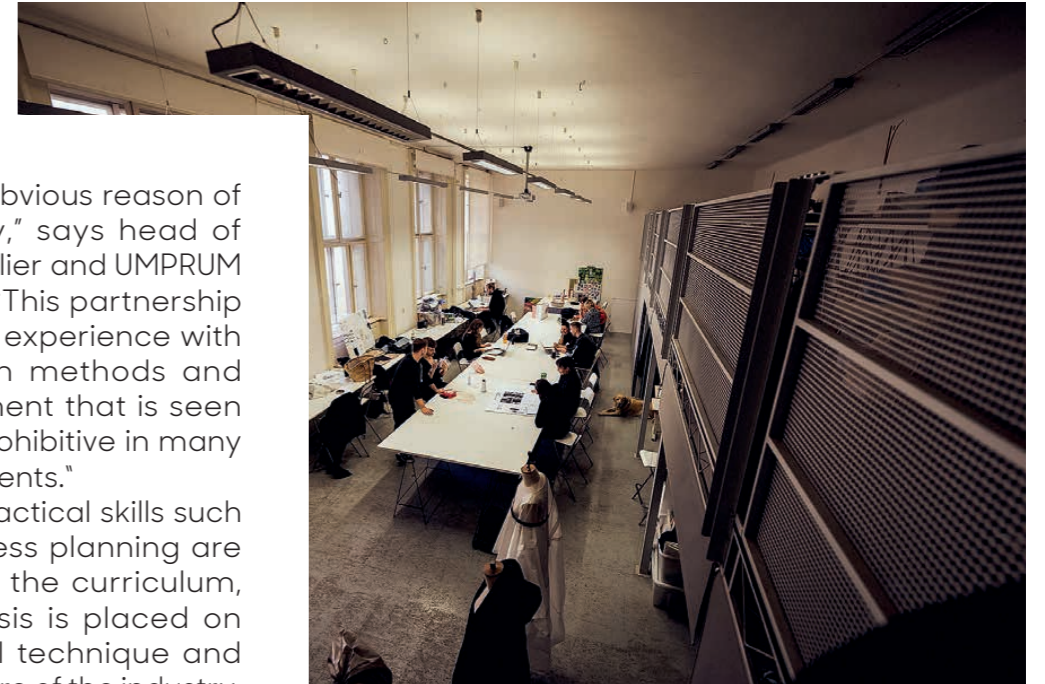

 PRECIOSA  
RE/INVENTORY







## POLYCHROMATIC COATINGS

for Chaton Roses MAXIMA and VIVA 12®

Back by popular demand, Polychromatic coatings Bermuda Blue, Vitrail Medium and Vitrail Light naturally deviate in shade making these coatings the perfect choice for effervescent, multi-colored shine.

# SURREALISTIC SPARKLE







# Crystals on the Catwalk

SS 2023

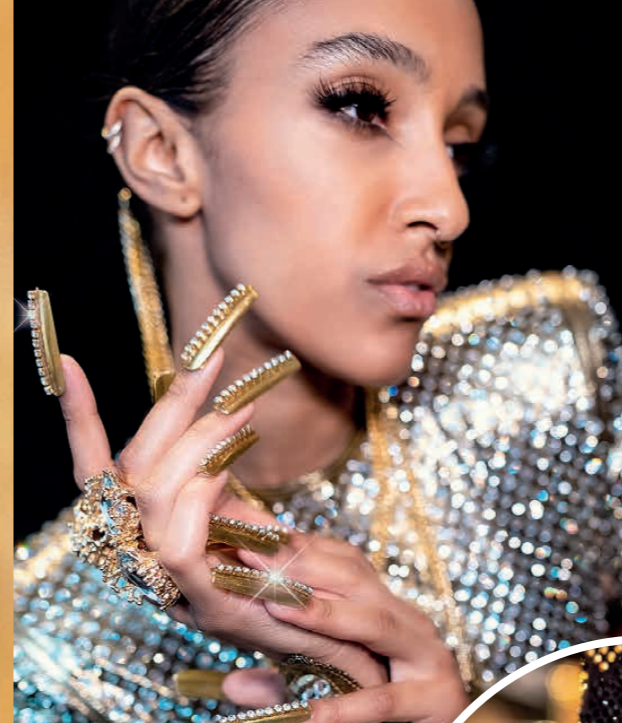

## The Blonds SS 2023

All that glitters was definitely gold at The Blonds' SS 2023 presentation, which culminated in a surprise, cupchain-clad performance by Saucy Santana. More than a dozen head-turning, Preciosa embellished looks illuminated the catwalk worn by a star-studded cast that included model and activist Munroe Bergdorf, beauty influencer Nikita Dragun and R&B artist Cassie. Among the most notable pieces were a black mini dress covered in The Blonds' logo written in gold Monte Carlo crystals and a fully crystalized jumpsuit in Blue Denim.

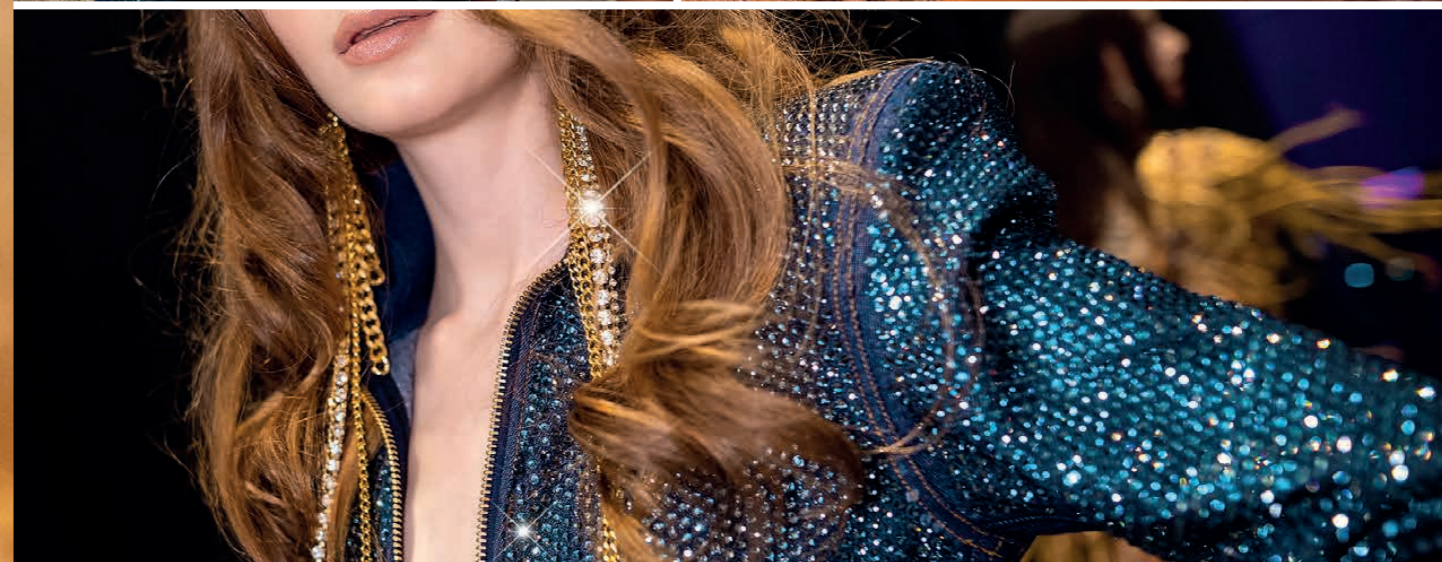





# Bibhu Mohapatra

SS 2023

Recognized throughout the fashion world as a virtuoso of detail, Bibhu Mohapatra's SS 2023 collection tended more toward couture than ready to wear. The designer's luxuriant fabrics were artfully enhanced with delicately placed Preciosa crystals, cupchains and beads that shimmered and sparkled down the catwalk, evoking a sense of playful refinement.

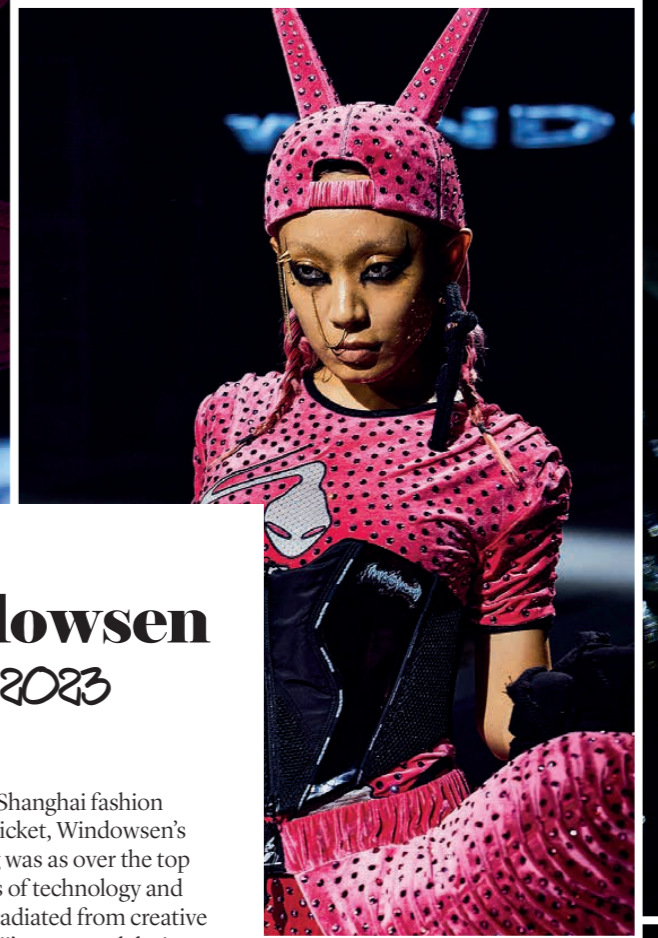
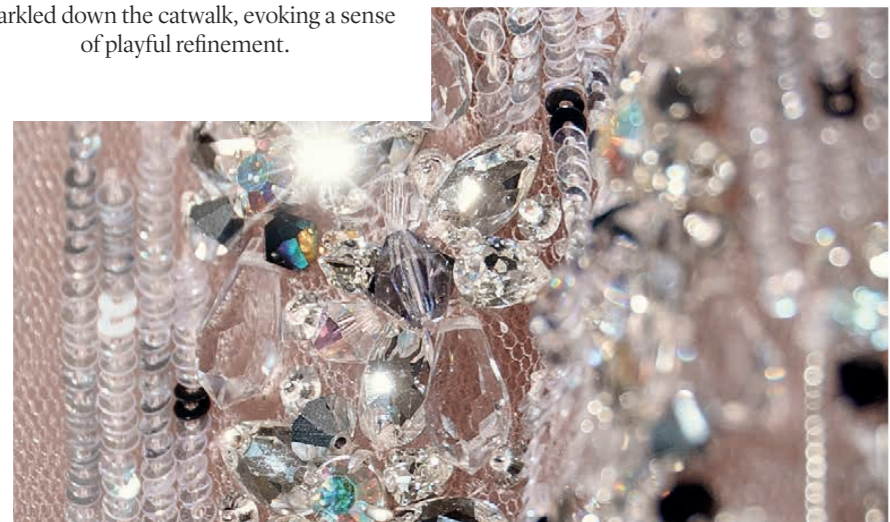

# Windowsen

SS 2023

Consistently Shanghai fashion scene's hottest ticket, Windowsen's SS 2023 showing was as over the top as ever. Themes of technology and otherworldliness radiated from creative director Sensen Lii's structural designs that were enlivened with thousands of hand-applied Preciosa crystals. Titled "THE REINCARNATION OF MX RIDICULOUS," this season's collection included everything from crystal-studded mermaid skirts emblazoned with custom crystal logo transfers.

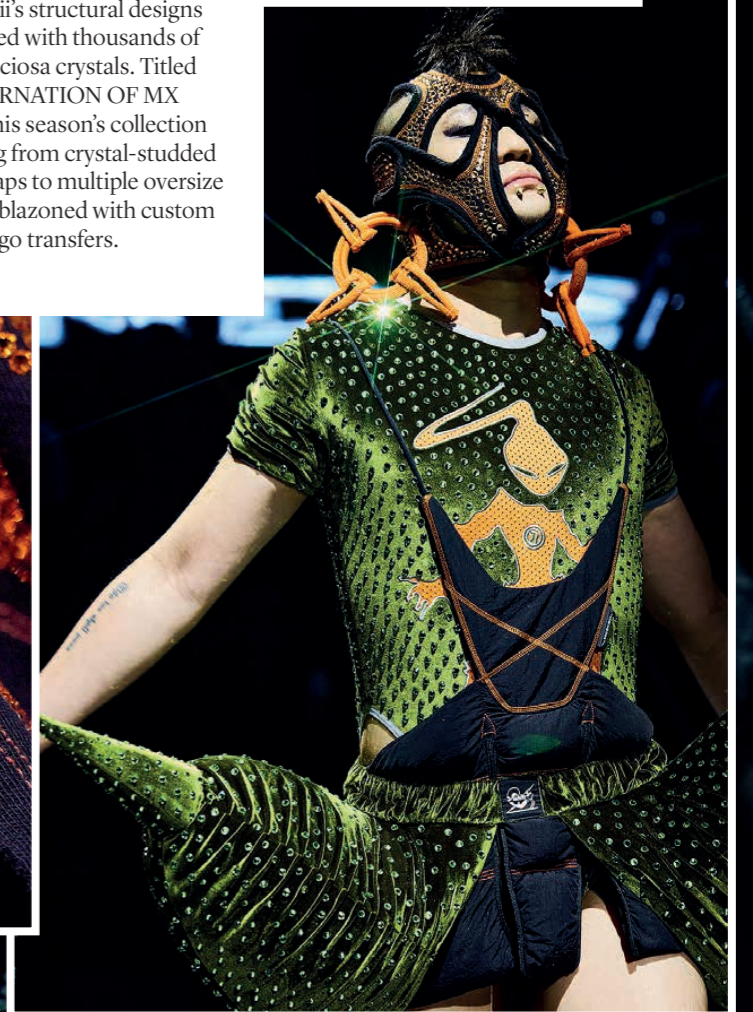
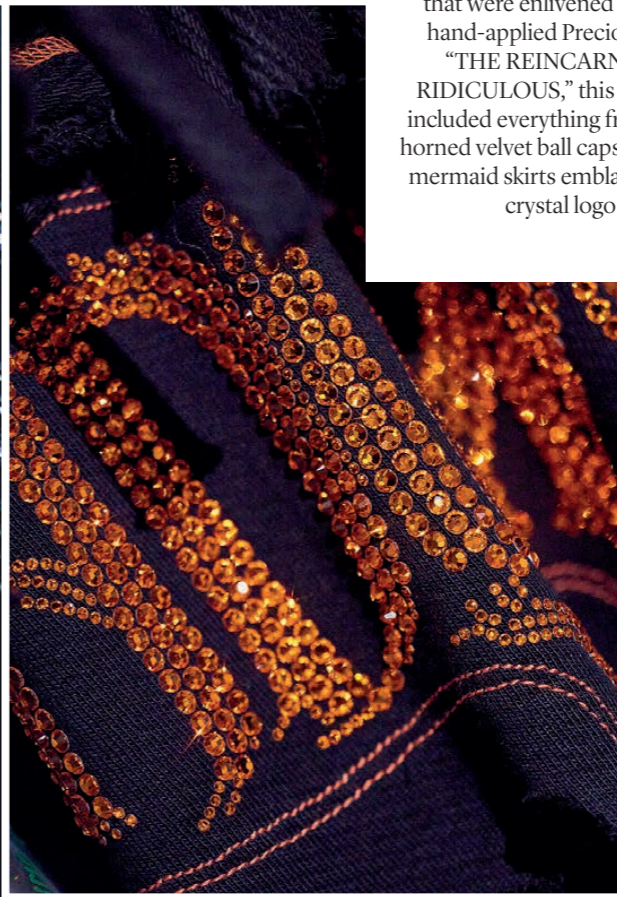



# The Preciosa Group

A global leader in luxury goods manufactured from crystal, the Preciosa Group stands upon centuries of glassmaking tradition and innovation. From the world's smallest faceted flatback stone to our cutting-edge, bespoke lighting installations, Preciosa looks to our own unique heritage to draw inspiration for the future of responsibly crafted Bohemian crystal. Together, the Group operates regional offices across Europe, North America and Asia and melts 40 tons of glass every day.



## Headquarters

Opletalova 3197/17  
46601 Jablonec nad Nisou  
Czech Republic

## Prague

Work Lounge at Forum Karlin  
Pernerova 51  
18600 Praha 8  
Czech Republic

## Dubai

GB-7/RA-8, Jebel Ali Free Zone  
P.O. Box 18185 Dubai  
United Arab Emirates

## Hong Kong

Unit 2306-2308, Enterprise Square 2  
3 Sheung Yuet Rd, Kowloon Bay  
Hong Kong S.A.R., China

## Dongguan

Dayuling Road  
Wen Tang Industrial Zone, Dongcheng  
523121 Dongguan, Guangdong Province  
China

## Guangzhou

Room 2009, Goldlion Digital Network Center  
No. 138, Tiyu Road East, Tianhe  
510000 Guangzhou, Guangdong Province  
China

## Yiwu

Room 8312,3/F, No. 1399, North Chouzhou Rd  
322000 Yiwu, Zhejiang Province  
China

## Seoul

Rom No. 921, New Hainam Bldg. 64  
Sejong-daero, Jung-gu  
04526 Seoul  
South Korea



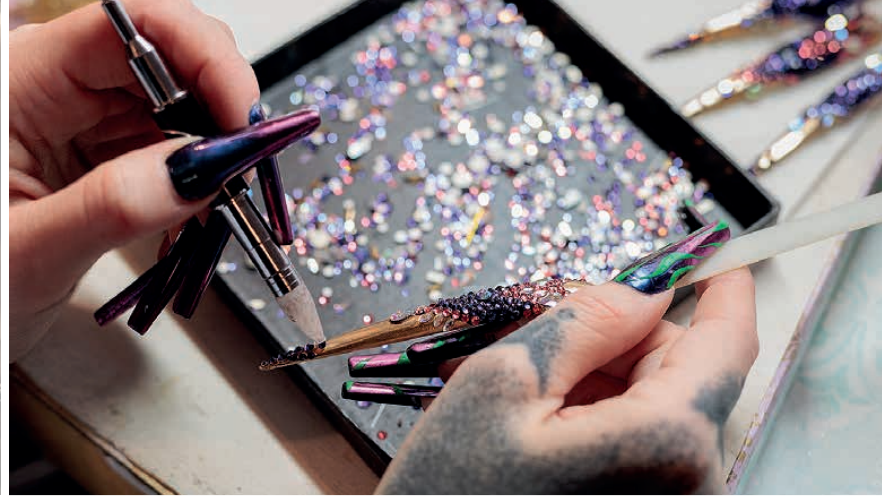

PRECIOSA

[PreciosaComponents.com](http://PreciosaComponents.com)